



Global Consulting Inc.

"Managing projects to success"

2-PC FLANGE BALL VALVE



Global Consulting Inc.
"Managing Projects to Success"

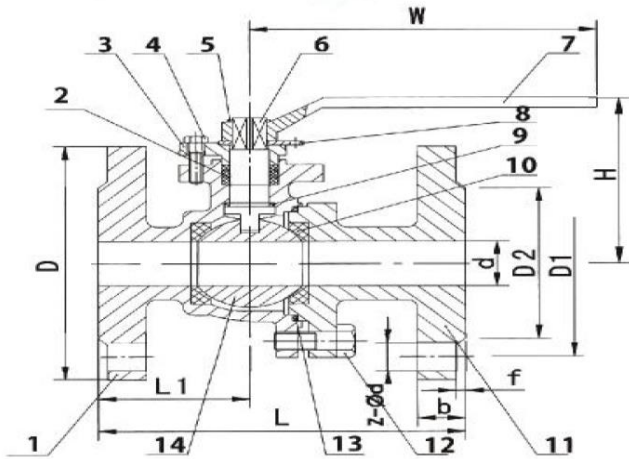

DIMENSION LIST

| SIZE | d | L | D | D1 | D2 | b | f | 2-Ød | H | W | Kgs |
|--------|-----|-----|-----|-------|-----|----|---|-------|-----|------|--------|
| 1/2" | 15 | 108 | 89 | 60.5 | 35 | 11 | 2 | 4-Ø15 | 65 | 120 | 1.80 |
| 3/4" | 20 | 117 | 98 | 70 | 43 | 11 | 2 | 4-Ø15 | 70 | 130 | 3.00 |
| 1" | 25 | 127 | 108 | 79.5 | 51 | 12 | 2 | 4-Ø15 | 85 | 130 | 4.50 |
| 1-1/4" | 32 | 140 | 117 | 89 | 64 | 13 | 2 | 4-Ø15 | 100 | 160 | 5.50 |
| 1-1/2" | 40 | 165 | 127 | 98.5 | 73 | 15 | 2 | 4-Ø15 | 120 | 205 | 5.80 |
| 2" | 50 | 178 | 152 | 120.5 | 92 | 16 | 2 | 4-Ø19 | 130 | 205 | 8.90 |
| 2-1/2" | 65 | 190 | 178 | 139.5 | 105 | 18 | 2 | 4-Ø19 | 140 | 210 | 9.80 |
| 3" | 80 | 203 | 190 | 152.5 | 127 | 19 | 2 | 4-Ø19 | 170 | 300 | 17.00 |
| 4" | 100 | 229 | 229 | 190.5 | 157 | 24 | 2 | 8-Ø19 | 205 | 300 | 26.20 |
| 5" | 125 | 356 | 254 | 216 | 186 | 24 | 2 | 8-Ø22 | 260 | 800 | 39.10 |
| 6" | 150 | 394 | 279 | 241.5 | 216 | 26 | 2 | 8-Ø22 | 350 | 900 | 58.20 |
| 8" | 200 | 457 | 343 | 298.5 | 270 | 29 | 2 | 8-Ø22 | 500 | 1000 | 102.60 |

KSPM-32

2-pc Flange Ball Valve

- Investment casting for body and cap
- Full bore
- Flanged ends ANSI B16 5
- Face to Face ANSI B16 10
- Pressure rating 150 LB
- Working temperature -25°C + 180°C
- Material CF8M, CF8, CF3M, WCB

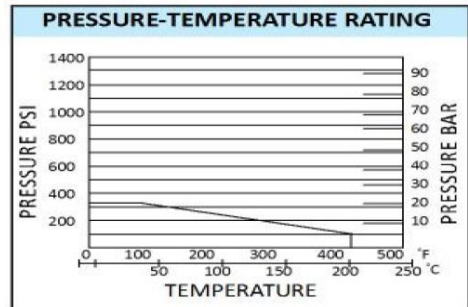

MATERIAL LIST

| ITEM | PART | MATERIAL | QTY |
|------|---------------|-----------|------|
| 1 | Body | CF8M | 1 |
| 2 | Steam Packing | PTFE | 1 |
| 3 | Gland | CF8M | 1 |
| 4 | Gland Bolt | SS304 | 2 |
| 5 | Snap Ring | SS304 | 1 |
| 6 | Stem | SS316 | 1 |
| 7 | Handle | SS/CS | 1 |
| 8 | Stoper | SS304 | 1 |
| 9 | Thrust Washer | PTFE | 1 |
| 10 | Ball Seat | R-PTFE15% | 2 |
| 11 | Cap | CF8M | 1 |
| 12 | Bolt | SS304 | 4(6) |
| 13 | Body Gasket | PTFE | 1 |
| 14 | Ball | SS316 | 1 |



Kspm Global Consulting Inc.

Head Office:

1113 Kestell Blvd., Oakville, Ontario L6H 7M6 Canada.

Website: www.kspmglobal.ca

E-mail: Operations@kspmglobal.ca